

PORCH
solutions^{by}



TRIMAX

Installation Instructions

The following installation instructions should be carefully adhered to. Please follow local building codes as well as good basic building practices.

Porch Solutions by **TRIMAX**

Tools

Porch Solutions can be installed with the same common tools used to install wood or alternative types of porch flooring.

Preparation

- To insure proper drainage joists should be sloped away from the house at ¼” per foot.
- Joists should be spaced at a maximum of 16” on center. For diagonal porch flooring installations the joists must be a maximum of 12” on center.
- For existing porches it is recommended to remove the existing flooring prior to installing Porch Solutions. Porch Solutions should not be installed over existing flooring.
- It is recommended that extra blocking be used to support any porch columns or posts that support the roof or a railing system.
- It is also recommended that extra framing and support be added to support the perimeter of the porch if a knee wall is being used.
- Perpendicular Application: Use a double joist at the house. Leave a ¼” space at the house and screw into both joists.

Expansion & Contraction

Porch Solutions is made from High Density Polyethylene. HDPE will experience minimal expansion and contraction in the lengths provided (8’ & 12’). In installations where one continuous piece cannot be used we recommend that you adhere to the following application guidelines for butt joints and miter joints. (Installations below 32 degrees leave a 3/16" gap. Installations between 32 and 75 degrees leave a 1/8" gap. Installations above 75 degrees leave a 1/16" gap.)

Fasteners

- Use a minimum of a #7 x 2” Stainless Steel Trimhead screw with a #17 drill point.
- If a pneumatic flooring nailer is used, it is recommended to use a barbed or serrated 2” stainless steel cleat T nail.

Installation

- Porch Solutions is a one-sided product. Install the embossed wood grain side up.
- If installing perpendicular to the house leave a ¼” gap between the flooring and the house siding.
- Attach the first porch board by screwing down through the board at the edge nearest the groove. (See Diagram “A”)
- Each subsequent porch board should be attached by driving the fastener through the tongue at a 30 to 45 degree angle.
- The fasteners should sit approximately 1/16” into the surface just above the tongue as shown in diagram “A” to allow for the installation of the next board.

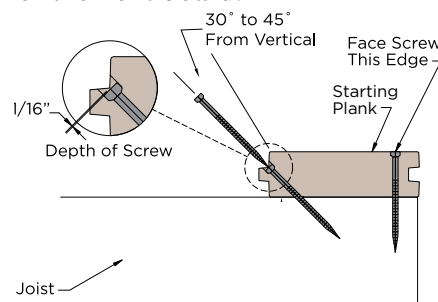
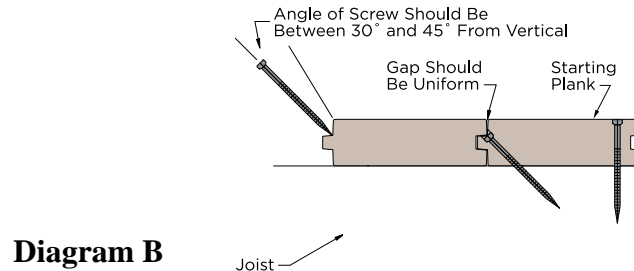

Diagram A

Installation (continued)

- Porch Solutions must be fastened to each joist!
- Install the next board by inserting the grooved edge over the exposed tongue on the first board. To insure a consistent seam it might be necessary to apply light pressure to the edge prior to fastening. Remember to seat the fasteners 1/16" into the surface as shown in diagram "A" to allow for the ease of installing the next board.
- Continue to install boards as shown in Diagram "B" until finished. Please note that the final board might need to be ripped in width. This board can be attached through the face or toe fastened through the ripped edge.



Trim Detail

- To finish off or picture frame your porch use the CTM25 (1/2" x 2 1/2" x 12'), See Diagram "C" or CTT110 (5/8" x 9 1/2" x 12'), see Diagram "D" available in all 3 colors.
- Porch Solutions can be used as stair treads. Note: Stair Stringers must be spaced a maximum of 12" on center.
- Porch Solutions is also available in a matching embossed stair tread (Gray & Teak Only). PLST (1 1/4" x 5 1/8")
- Note: Check with your local code officials pertaining to specific stair and associated railing requirements.

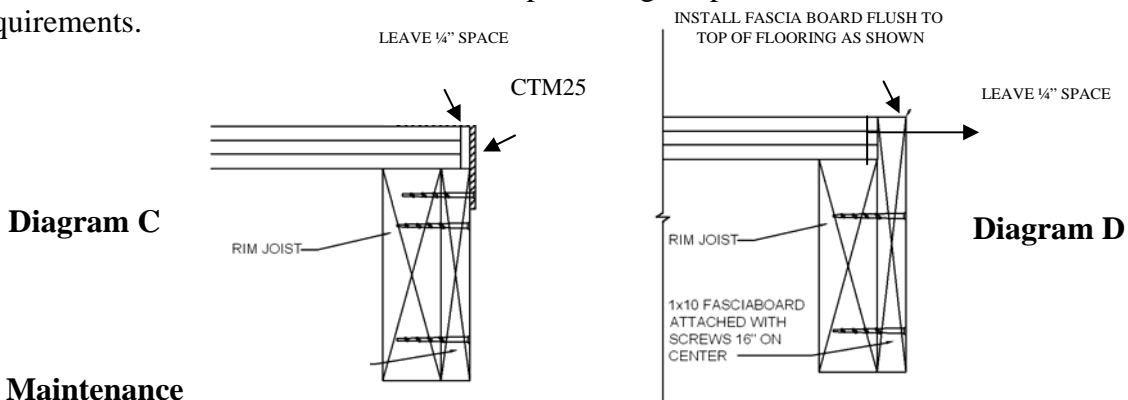

Care and Maintenance

- To clean Porch Solutions use a mild liquid soap, garden hose and a soft brush.
- Avoid any abrasive type cleaners and avoid high pressure power washers to avoid damage to the decking as well as the siding.

Warranty

Twenty Five/Two Year Warranty. Trimax warrants that its Porch Solutions HDPE porch flooring will not rot, mold, peel, splinter, fade or suffer defects from termites or fungal decay. Porch Solutions must be installed as per the Porch Solutions installation guide and the following of good basic building practices. The twenty five year warranty shall apply to replacement material only. In addition, a Two year labor allowance not exceeding two times the reasonable Trimax product material purchase cost shall be applicable for the first two years of installation. Complete warranty information is available at www.trimaxbp.com.

Distributed by

